



- **Low Air Consumption**
- **Low Noise Level**
- **Easy Installation**
- **Instantly Start & Stop**
- **For Dosing and Conveying**

### **FlexiLink resonance system for NTK piston vibrators**

The FlexiLink system offers superior brute force vibration in conjunction with the pneumatic NTK vibrator and blade springs

FlexiLink resonance system is widely used as drive for vibration chutes, conveyors, dosing and sieves

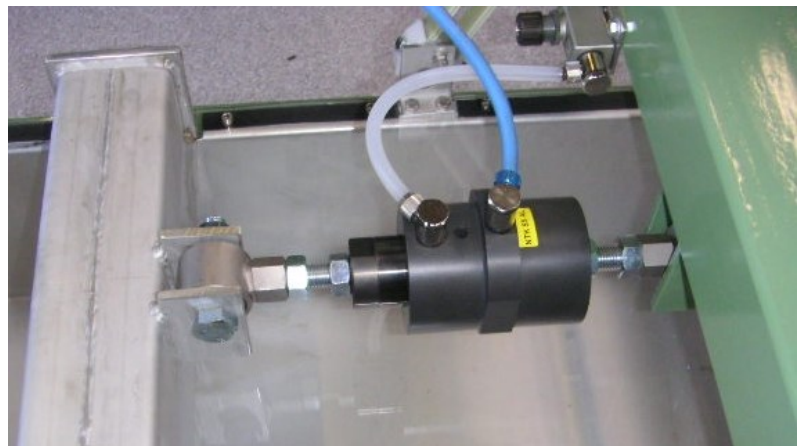
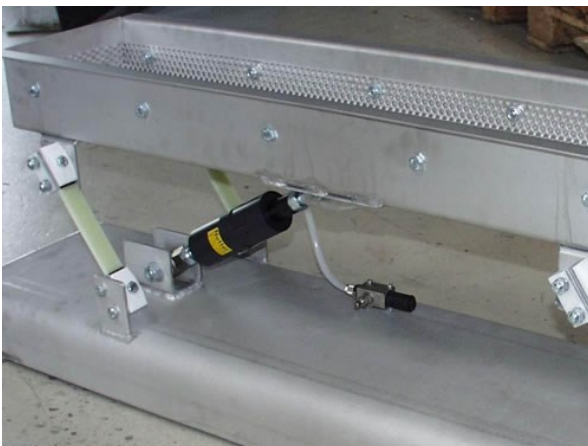

# FlexiLink

## Applications

FlexiLink is the optimal vibration solution in many productions and application

- Granulates and Powders
- Vegetables
- Berries
- Pellets
- Food Production
- All kind of bulk materials

FlexiLink ensures a gentle and cost efficient handling and conveying of all products

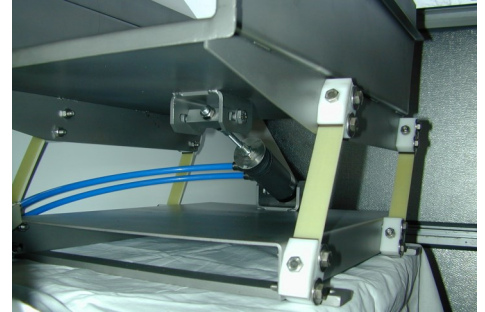

## FlexiLink Resonance System consist of the following equipment

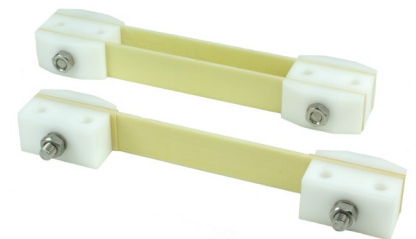
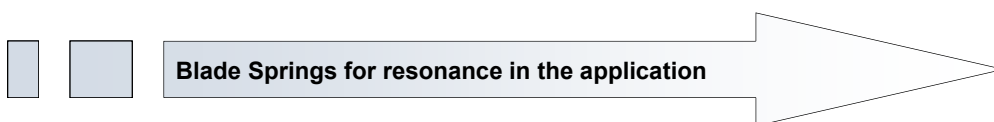
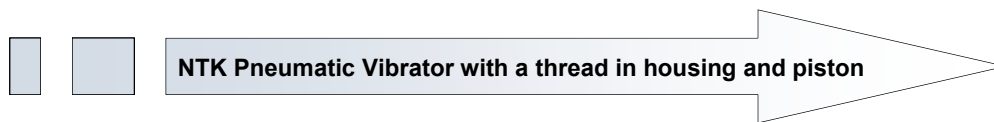

These three FlexiLink components is dimensioned and configurator specifically to the customers application

Copenhagen Vibrator Products will of course help you for optimal solution and consulting

## Function

The FlexiLink components is installed according to the instructions from Copenhagen Vibrators Products.

The powerful brute force vibration is created in conjunction between the NTK vibrator and the blade springs.

The resonance vibration will then be transferred directly to the conveyor.

The FlexiLink drive hardly needs any maintenance, lubrication of the NTK vibrator is recommended for longevity.

The speed and stroke of the conveyor is easily adjustable with a filter regulator for the compressed air.

When the conveyor is started and operating, the vibrations system will create a self-reinforcing vibration with low compressed air consumption, even with varied load.

# FlexiLink

Distance "A" is only referred as the standard positioning of the piston

In most cases it is necessary to re-positioning the piston "A" to ensure optimal start-position of the NTK vibrator

Distance "A" can vary - / + 0,5 mm.

## FlexiLink M20

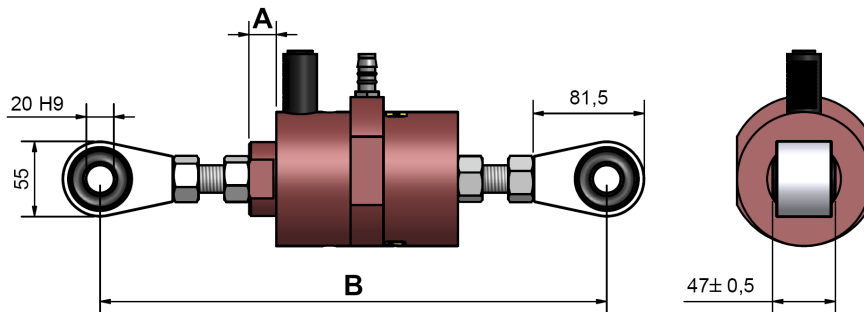

Vibrator	Distance "A"	Distance "B" Max.	Distance "B" Min.
NTK 55 HF	38mm.	378mm.	350mm.
NTK 55 NF	38mm.	387mm.	367mm.
NTK 55 AL	38mm.	395mm.	373mm.
NTK 85 HF	38mm.	375mm.	350mm.
NTK 85 NF	38mm.	385mm.	360mm.
NTK 110	38mm.	385mm.	360mm.

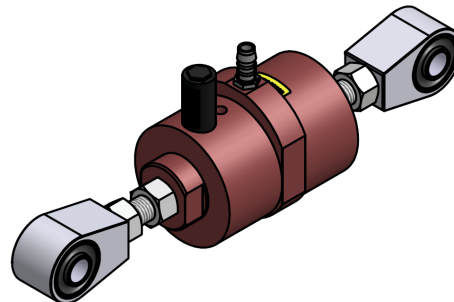

## FlexiLink M16

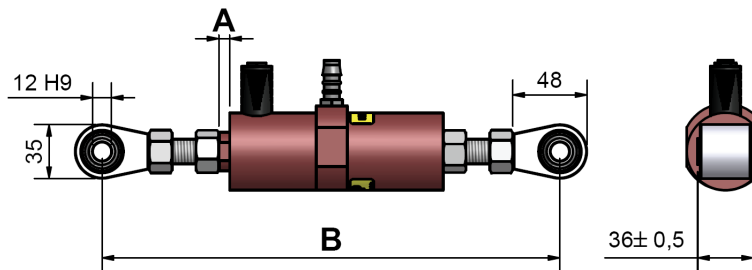

Vibrator	Distance "A"	Distance "B"
NTK 25	37,5mm.	318mm.
NTK 25 AL	37,5mm.	312mm.
NTK 40	37mm.	315mm.
NTK 40 AL	37mm.	315mm.

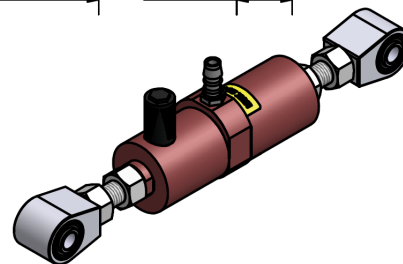

## FlexiLink M10

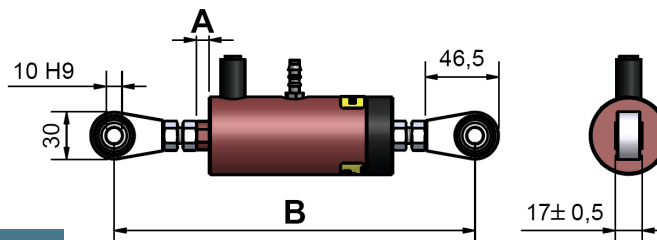

Vibrator	Distance "A"	Distance "Y"
NTK 15 X	29,5mm.	270mm.
NTK 16	29,5mm	267mm.
NTK 18 AL	29,5mm	273mm.

